

# VDA-PMT-AIDOME Indoor Pipe Mount

www.boschsecurity.com



**BOSCH**  
Invented for life



- ▶ Hollow core for cable-free appearance
- ▶ Tough 4-bolt anchoring
- ▶ Anti-rust treated
- ▶ Metric/imperial thread adapter included

This pipe mount is specifically designed for indoor dome cameras.  
An adapter is included to convert between metric and imperial thread sizes (M35 female to 3/4 inch female).

## Installation/configuration notes

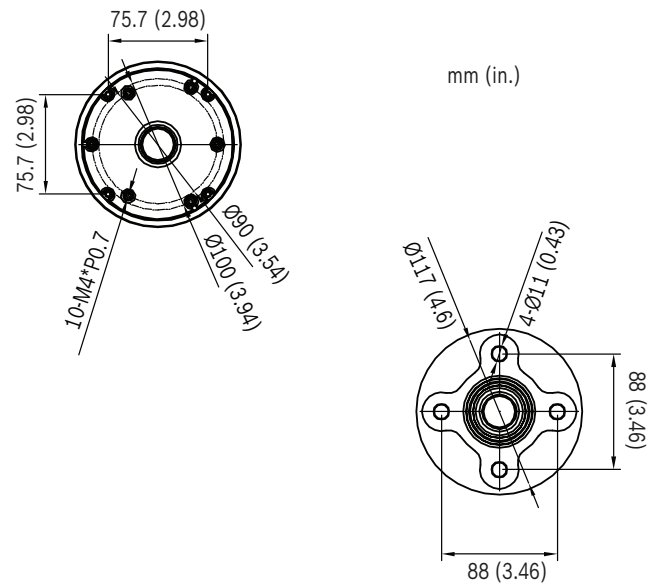

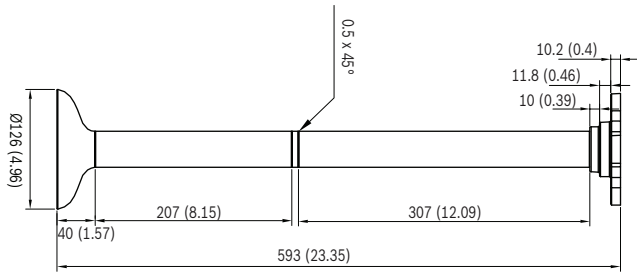

### Parts included

The packaging contains:

Qty	Component
1x	Pipe mount
1x	Pipe thread adapter (M35 female to 3/4 inch female)
	Attachment components

### Technical specifications

Construction material	Aluminum alloy
Finish	RAL 9003 signal white

### Ordering information

#### VDA-PMT-AIDOME Indoor Pipe Mount

Indoor pendant pipe mount for dome cameras (Ø166 mm); use together with the appropriate adapter bracket

Order number **VDA-PMT-AIDOME**

#### Represented by:

**North America:**  
 Bosch Security Systems, Inc.  
 130 Perinton Parkway  
 Fairport, New York, 14450, USA  
 Phone: +1 800 289 0096  
 Fax: +1 585 223 9180  
 security.sales@us.bosch.com  
 www.boschsecurity.us

**Europe, Middle East, Africa:**  
 Bosch Security Systems B.V.  
 P.O. Box 80002  
 5617 BA Eindhoven, The Netherlands  
 Phone: + 31 40 2577 284  
 Fax: +31 40 2577 330  
 emea.securitysystems@bosch.com  
 www.boschsecurity.com

**Asia-Pacific:**  
 Robert Bosch (SEA) Pte Ltd, Security Systems  
 11 Bishan Street 21  
 Singapore 573943  
 Phone: +65 6571 2808  
 Fax: +65 6571 2699  
 apr.securitysystems@bosch.com  
 www.boschsecurity.asia

**China:**  
 Bosch (Shanghai) Security Systems Ltd.  
 203 Building, No. 333 Fuquan Road  
 North IBP  
 Changning District, Shanghai  
 200335 China  
 Phone +86 21 22181111  
 Fax: +86 21 22182398  
 www.boschsecurity.com.cn

**Latin America and Caribbean:**  
 Robert Bosch Ltda Security Systems Division  
 Via Anhanguera, Km 98  
 CEP 13065-900  
 Campinas, Sao Paulo, Brazil  
 Phone: +55 19 2103 2860  
 Fax: +55 19 2103 2862  
 latam.boschsecurity@bosch.com  
 www.boschsecurity.com